

Installation and User Manual for Vice HV 519 , 519S, 581

Clamping system HV 519, 519S, 581 (see Fig. 1) :

- | | |
|------------------|---|
| 1. Line cassette | 5. Front board |
| 2. Face | 6. Head with hole for handle 28-25mm [1,102"- 0,984"] |
| 3. Spindle | 7. Securing pin |
| 4. Nut | 8. Cover vice |

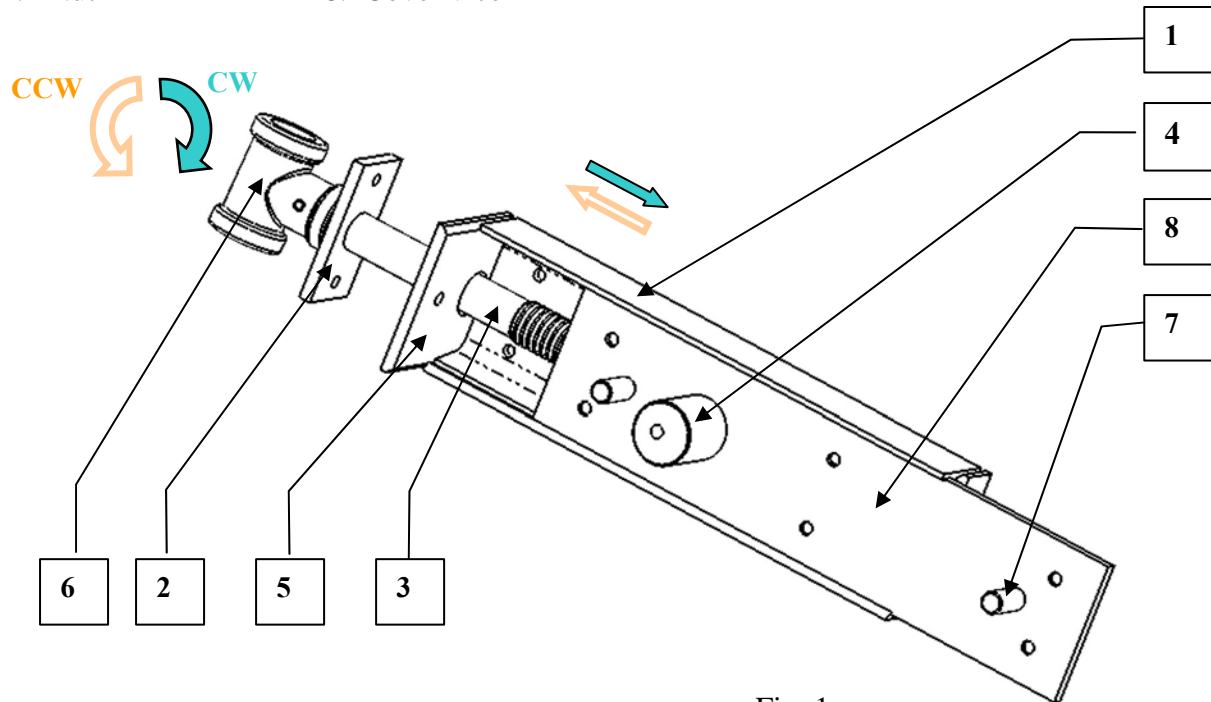

Fig. 1



1. Foreword:

Read carefully all instructions of this User Manual, especially sections concerning work safety. These sections are marked by a warning triangle.



2. Important notice !!

- the head (6) has an opening for the handle $\varnothing 28-25\text{mm}$ [1,102"- 0,984"]
- to ensure safe fixing of the vice, the minimum workbench or collar workbench thickness is **100mm** [3,937"]
- after unpacking, the vice must be cleaned of all preservative grease
- prior to installation, the HV vice must be dismantled into two parts turning the spindle clockwise (CW) until the entire cover (8) slides off the conduit cassette (1)
- assembly is done by reverse procedure and turning the spindle counter clockwise (CCW)
- vice installation is easier when the workbench is turned upside down
- to ensure correct vice operation it is recommended to lubricate the spindle (3) and guiding grooves of the conduit cassette (1) with oil **once a week**

3. Standard Clamping by Turning the Spindle

By turning the spindle (3) clockwise (CW) the vice clamp. By turning the spindle (3) counter clockwise (CCW) the vice disengage.

4. General Instructions

The wood vice is mounted to the lateral face of a workbench flush with the outside edge. The exact position is selected depending on the design of the workbench and HV vice size. Is recommended vice installation on **workbench with collar**. The most common HV vice installation is illustrated in Fig. 2a, 2b, 2c.

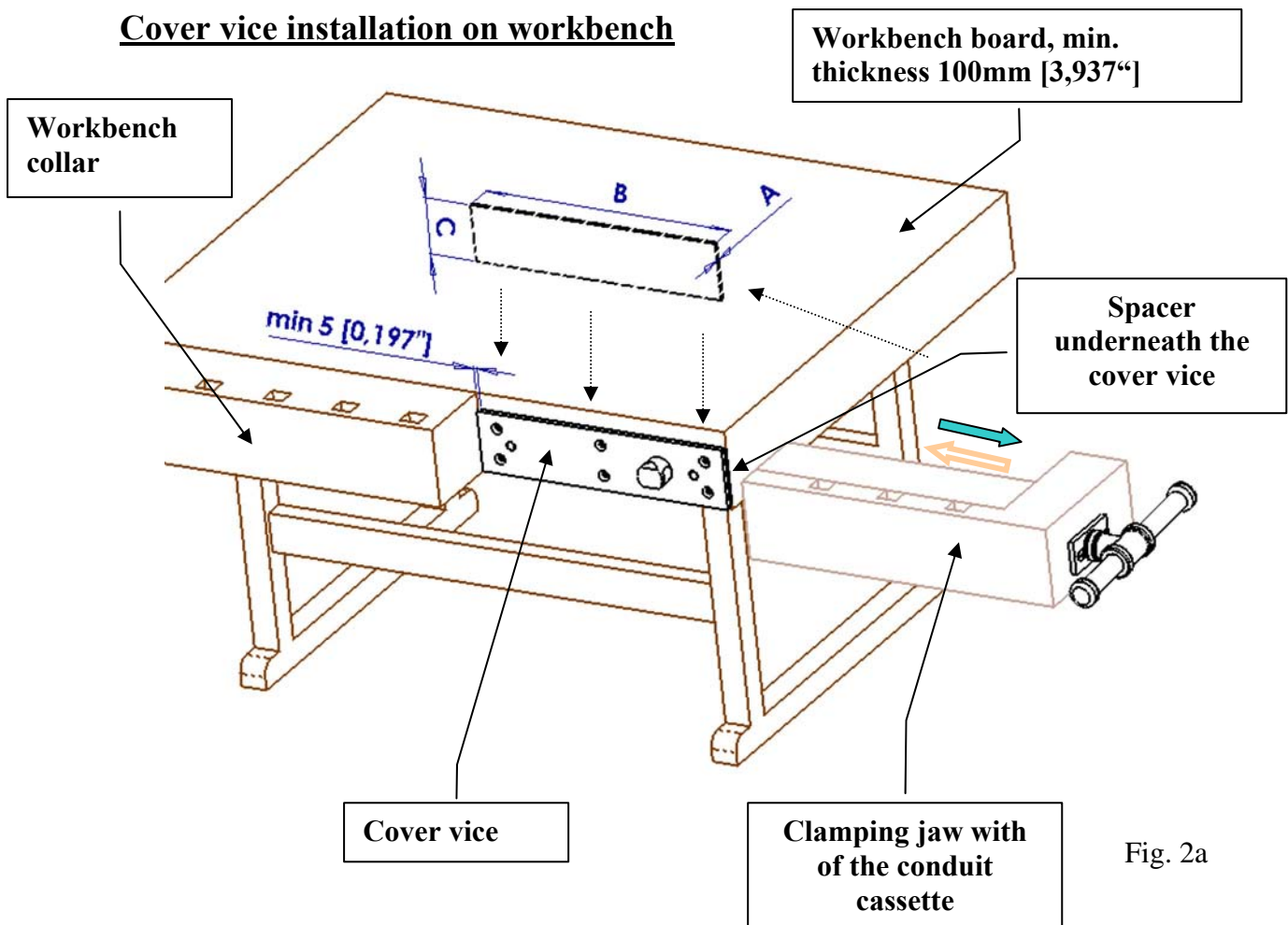

Spacer underneath the cover	min A mm ["]	min B mm ["]	C mm ["]
HV 519 a 519S	5 [0,197"]	395 [15,551"]	88 [3,465"]
HV 581	5 [0,197"]	348 [13,701"]	88 [3,465"]

Installation jaw with of the line cassette

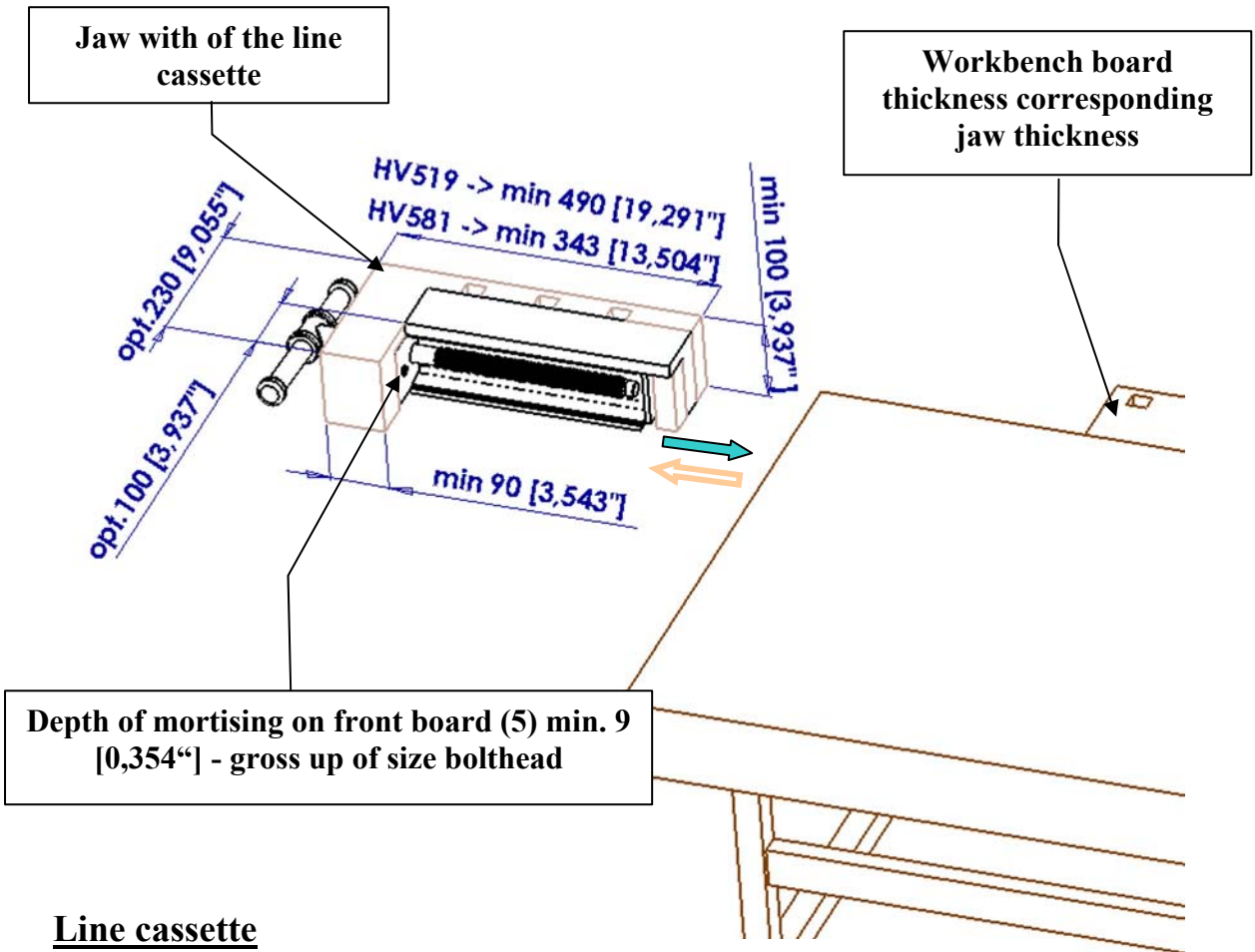

Line cassette

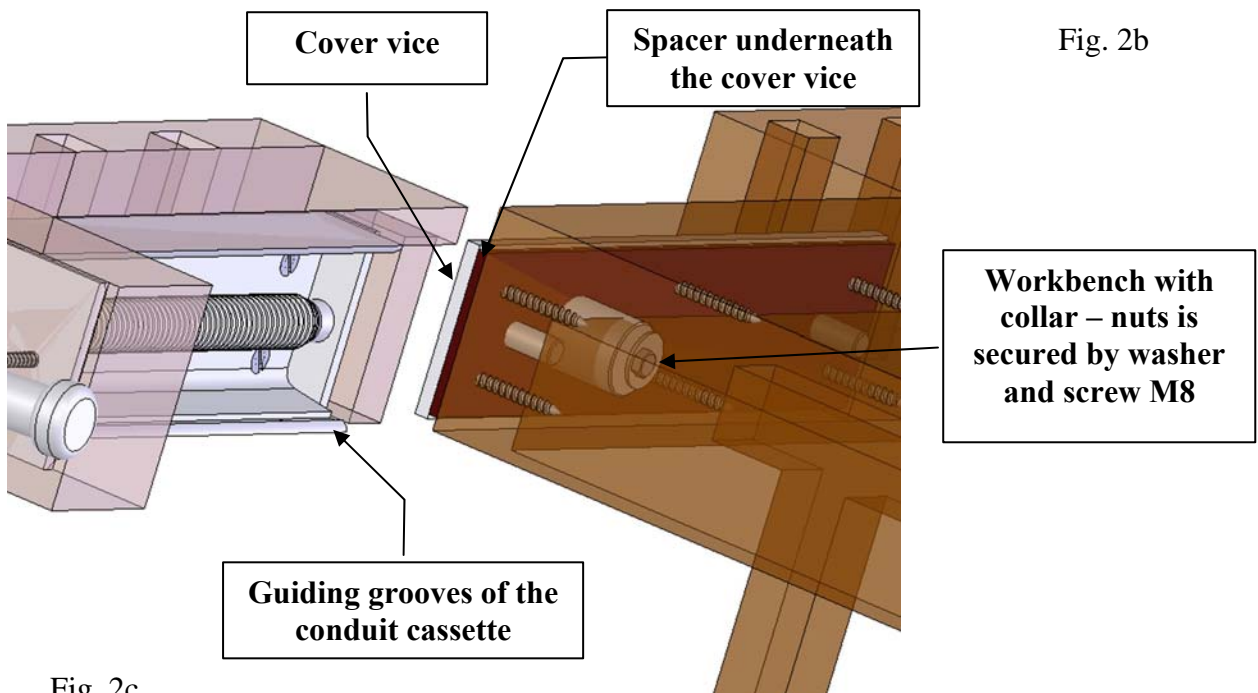

Fig. 2b

Fig. 2c

5. Dimensions and drilling of cover vice

The vice jaw and spacer should be made of fine-grained hard wood eventually plywood.



Fix the cover vice with spacer so that the top edge jaw is flush with the top of the workbench board. That's why should be made clamping jaw with of the conduit cassette with finish allowance. Dimensions spacer underneath the cover vice see page No.2, Fig.2a.



Fix the cover vice with spacer axially symmetrical so that spacer is not interfered a guiding grooves of the conduit cassette.

Cover vice use after screw as template drilling hole $\varnothing 14$ for securing pins (only HV519 and HV519S) at $\varnothing 40$ for nut. If the workbench has a collar, nut is secure sole piece and screw M8 from the inside the workbench. See Fig.2c. If the workbench has no collar it is possible nut use not securing (that is hardly mounting clamping jaw).

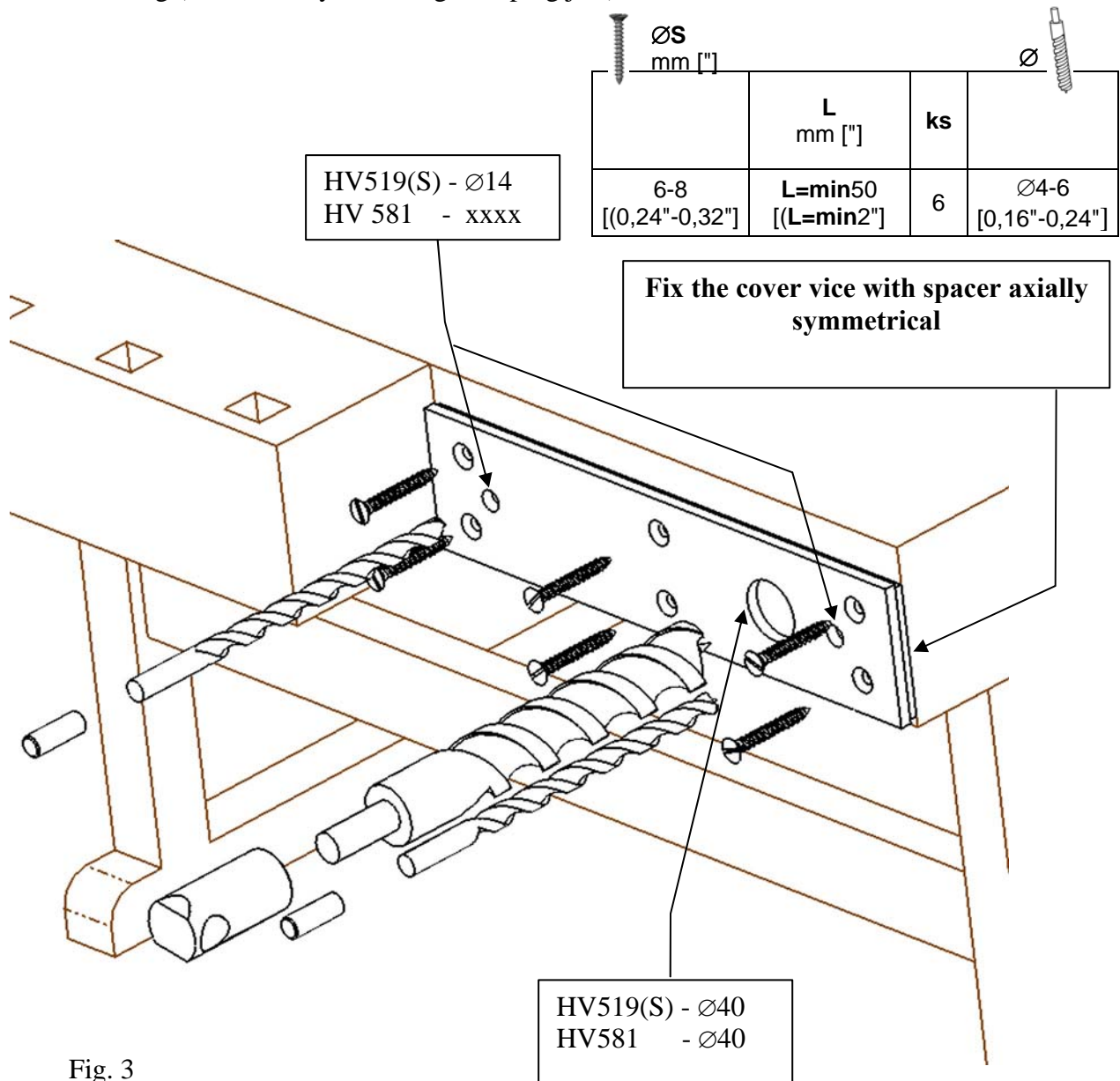
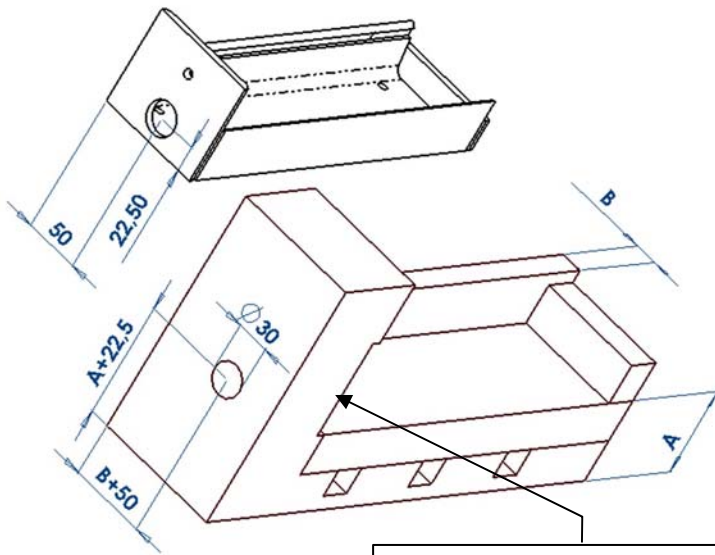

Fig. 3

6. Making clamping jaw with of the line cassette

Dimensions minimum and optimum clamping jaw see page No.3, Fig.2b. Making clamping jaw with of the line cassette is recommended made with finish allowance. First is make mortising on front board into clamping jaw, follow drilling hole for spindle ($\text{Ø}30$ for HV 519(S) and HV 581). See Fig.4a. Then is must insert eventually glue together to remainder parts. Finally, is screw the line cassette . See Fig.4b.



Mortising on front board (5) into clamping jaw

Fig.4a

	L mm["]	ks	
6-8 [0,24"-0,32"]	L=min50 [L=min2"]	5	Ø4-6 [0,16"-0,24"]

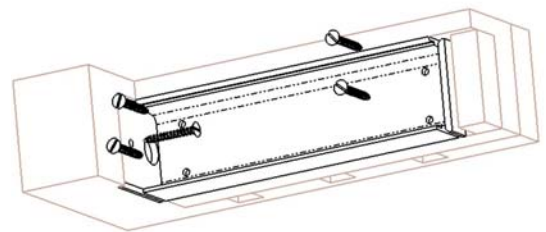

Fig.4b

7. Completion mounting clamping jaw

The spindle complet with face insert into hole clamping jaw. Position the face is parallel to jaw. The face screw-bolt.

ØS mm["]	L mm["]	ks	Ø mm["]
6-8 [0,24"-0,32"]	L=min50 [L=min2"]	2	Ø4-6 [0,16"-0,24"]

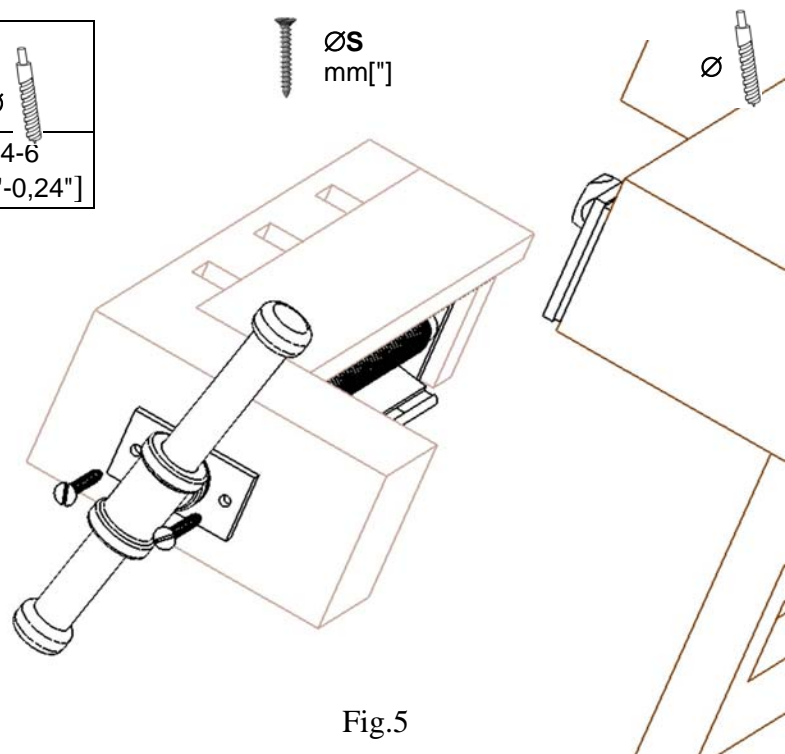

Fig.5

7. Vice installation on a workbench

Required tools:

- handheld drill / bench top upright drill
- wood drill bit \varnothing : 3, 4, 5, 6, 14, 30, 40 mm [0,12", 0,16", 0,2", 0,24", 0,55", 1,18", 1,58"]
- manual / electrical screwdriver – depending on type and size of used screws
- wood saw
- screw vice
- hammer / mallet
- wood screws \varnothing 6-8mm [0,24"-0,32"] - 13pcs - depending on type
- bolt M8

- If the workbench has a collar, nut is secure sole piece and screw M8 from the inside the workbench. If the workbench has no collar, spindle of the conduit cassette secure her position.
- Prior to bolting spindle and nut, the face must unfastening and spindle draw out. See Fig .6b.
- Vice installed insert clamping jaw to cover vice over hole for nut. Than follows put through nut. See Fig.6a a 6b.
- We bolt spindle and nut. We can fast the face screw-bolt again See Page 5, Fig.5.

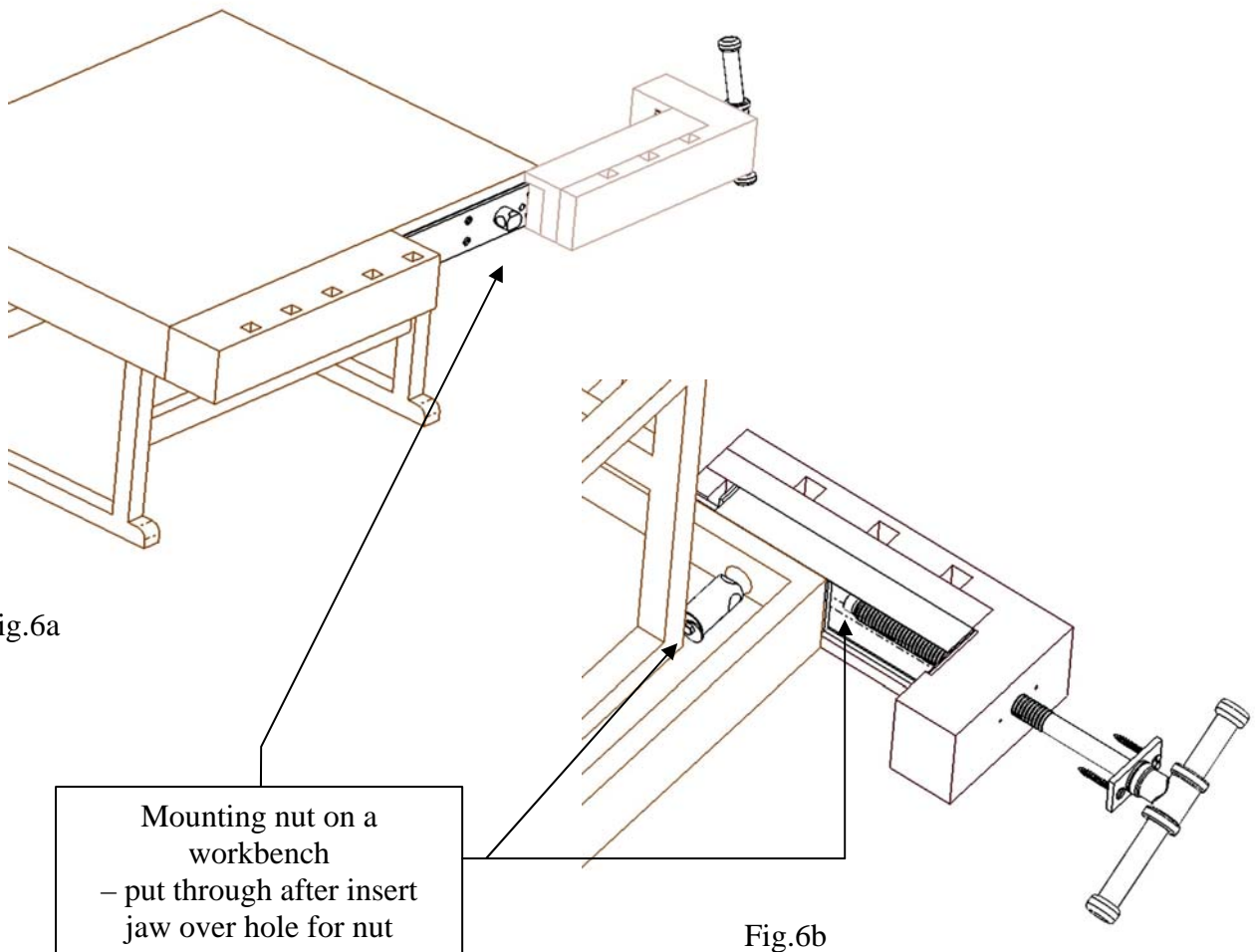

Fig.6a

Fig.6b

e) After tighten vice first is must to seat all edges of clamping jaw with the workbench board.
See Fig.7.

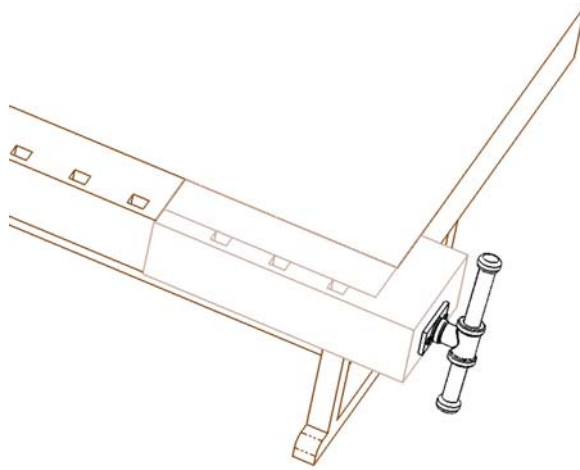

Fig.7

f) Finally, check the operation of the vice's system. By turning the spindle (3) clockwise (CW) the vice clamp. By turning the spindle (3) counter clockwise (CCW) the vice disengage.

Vice disassembly is done by reversing the steps described in this User Manual.